

P向局部

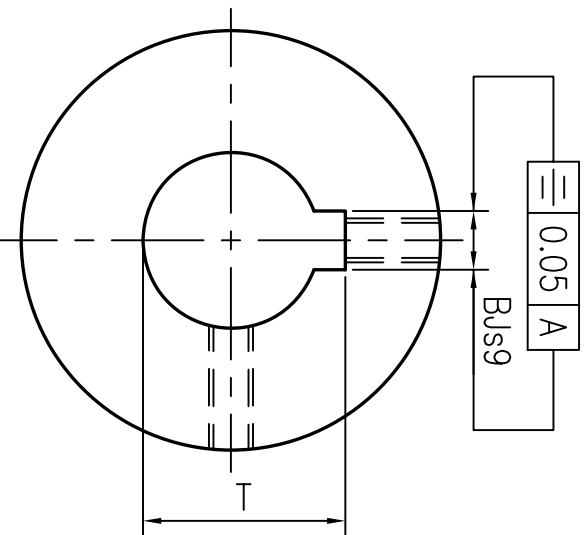

0.06 A

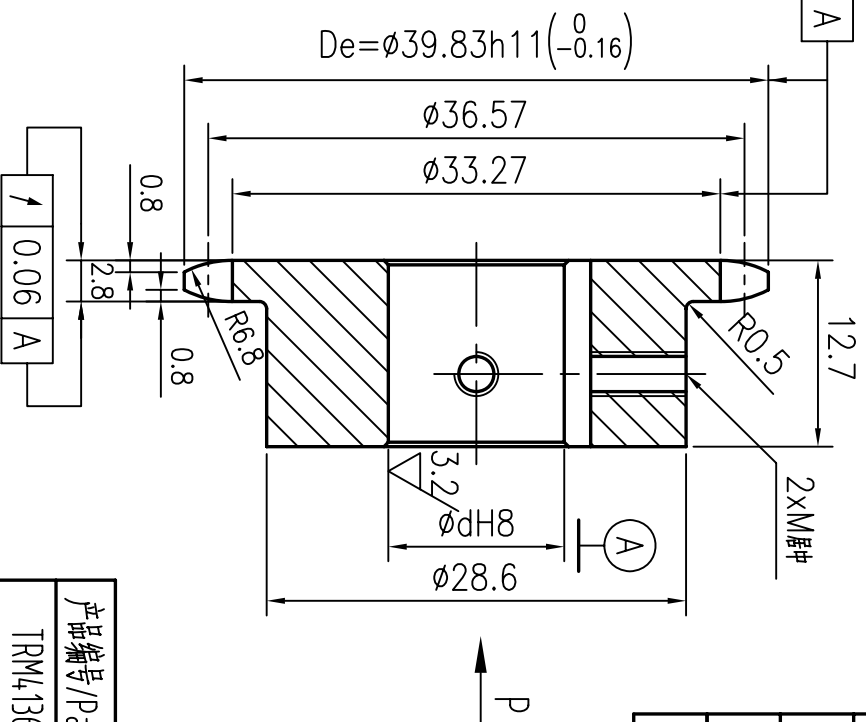

6.3/√ 其余

链轮齿数	Z	18
配用链条节距	P	6.35
配用链条滚子外径	d	φ3.3
测量距	Lx	33.27 ⁰ _{-0.12}
标准	ANSI B29.1:25B	

技术要求

- 1.未注倒角0.5,锐边倒钝去毛刺; Unquoted chamfer (0.5) break sharp edges
- 2.各表面不得有划伤,锈迹等缺陷; All surfaces must be rust free and no scratch
- 3.未注尺寸公差按ISO 2768-MK标准; dimensions without tolerance according to 2768-MK
- 4.齿部淬火处理HRc4.0~4.5,涂防锈油; Teeth induction hardened HRc4.0-4.5,coated with antirust oil;
- 5.产品打字,装配紧定螺钉,Marking part No,Set screws installed

标记	外数	更改文件号	签字	日期
设计	zhang	标准化		
审核	huang			
工艺				

名称/Name:	链轮
型号/Code:	25B,Z18
共	页
第	页

产品编号/Part No.	d	T	B	M
TRM4136_0	9 ^{+0.027} ₀	10.4 ^{+0.1} ₀	3±0.012	M3
TRM4140_0	12 ^{+0.027} ₀	13.8 ^{+0.1} ₀	4±0.015	M4

图号/Drawing No:	TRM4136_0~4140_0	更新/Rev	
材料/Material:	C45	重量	
		比例	2:1
Chengdu Leno Machinery Co.,Ltd Tel:+86-28-65998825; Fax:+86-28-84862968 sales@cleno.com; www.cleno.com			