

P向局部

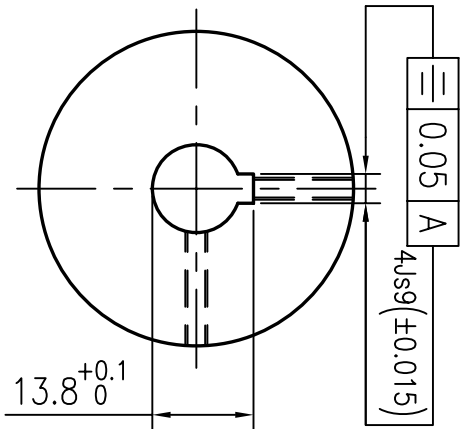

其余 6.3/3.2

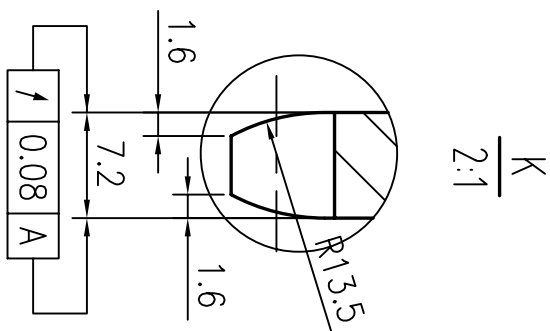
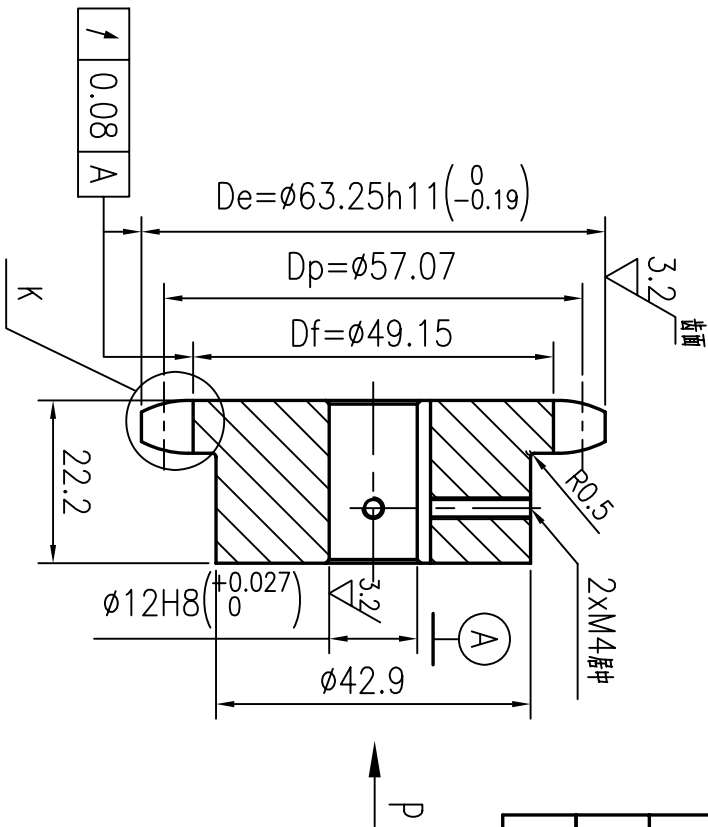

技术要求

1. 未注倒角0.5, 锐边倒钝去毛刺;
Unquoted chamfer (0.5), break sharp edges
2. 各表面不得有划伤, 锈迹等缺陷;
All surfaces must be rust free and no scratch
3. 未注尺寸公差按ISO 2768-MK标准;
dimensions without tolerance according to 2768-MK
4. 齿部淬火处理HRC4.0~4.5, 涂防锈油;
Teeth induction hardened HRC4.0-4.5, coated with antirust oil;
5. 产品打字, 装配紧定螺钉; Marking part No, Setscrews installed

名称/Name:		链轮	
型号/Code:		40B,Z14	
图号/Drawing No:	TRM4145_0	材料/Material:	C45
更新/Rev		重量	比例
			1:1
标记/处数	更改文件号	签字	日期
设计	Zhang		
审核	huang		
工艺		日期	
共 页		第 页	
标准		ANSI B29.1:40B	
测量距		Lx	
标准		ANSI B29.1:40B	
链轮齿数		Z	
Z		14	
配用链条节距		P	
P		12.7	
配用链条滚子外径		d	
d		φ7.92	
测量距		Lx	
Lx		49.15-0.19	
标准		ANSI B29.1:40B	