

技术要求

- 1.未注倒角0.5,锐边倒钝去毛刺;
- Unquoted chamfer (0.5) break sharp edges
- 2.各表面不得有划伤,锈迹等缺陷;
- All surfaces must be rust free and no scratch
- 3.未注尺寸公差按ISO 2768-MK标准;
- dimensions without tolerance according to 2768-MK
- 4.齿面淬火处理HRc4.0~4.5,涂防锈油;
- Teeth induction hardened HRc4.0-4.5,coated with antirust oil;
- 5.产品打字,装配紧定螺钉,Marking part No, Setscrews installed

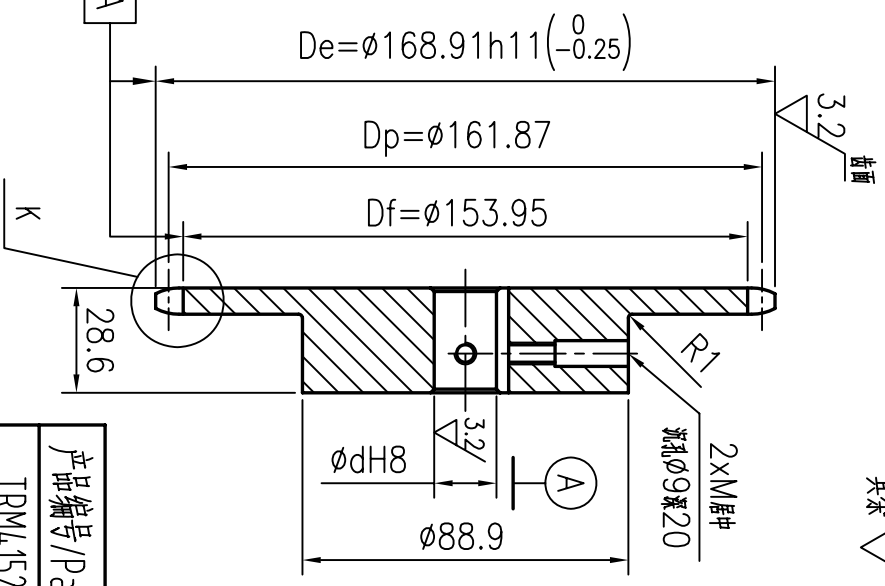

链轮齿数	Z	40
配用链条节距	P	12.7
配用链条滚子外径	d	$\phi 7.92$
测量距	Lx	$153.95_{-0.25}^0$
标准	ANSI B29.1, 40B	

产品编号/Part No.	d	T	B	M
TRM4152_0	$17_{0}^{+0.027}$	$19.3_{0}^{+0.1}$	5 ± 0.015	M5
TRM4156_0	$25_{0}^{+0.033}$	$28.3_{0}^{+0.2}$	8 ± 0.018	M8

名称/Name: 链轮		型号/Code: 40B,Z40	
图号/Drawing No: TRM4152_0~4156_0	材料/Material: C45	重量	比例 1:2
产品编号/Part No.	d	T	B
TRM4152_0	$17_{0}^{+0.027}$	$19.3_{0}^{+0.1}$	5 ± 0.015
TRM4156_0	$25_{0}^{+0.033}$	$28.3_{0}^{+0.2}$	8 ± 0.018
设计	更改文件号	签字	日期
zhang	zhang	huang	huang
审核	日期	日期	日期
工艺	日期	日期	日期

