

P向局部

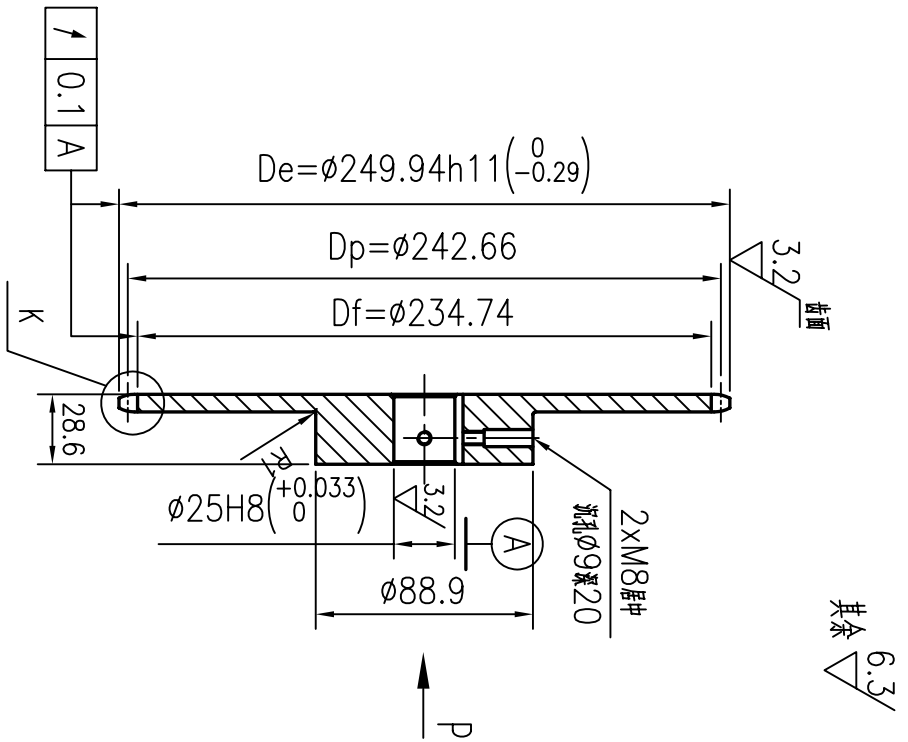

其余 6.3/ 齿面

链轮齿数	Z	60
配用链条节距	P	12.7
配用链条滚子外径	d	φ7.92
测量距	Lx	234.74 ⁰ _{-0.29}
标准	ANSI B29.1, 40B	

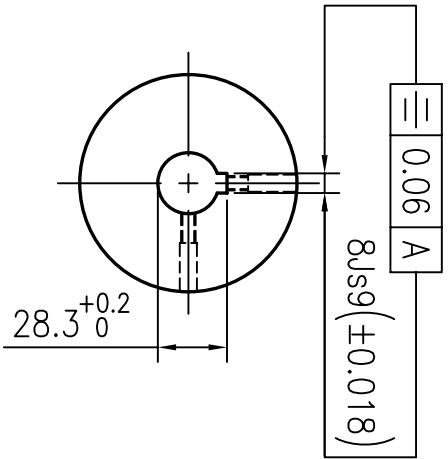
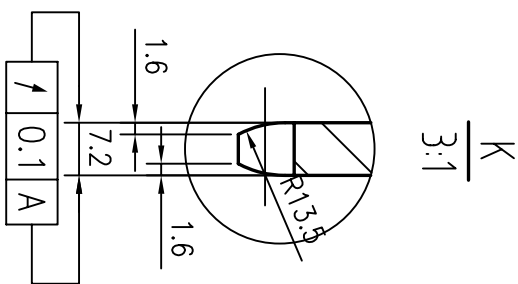

技术要求

- 1.未注倒角0.5,锐边倒钝去毛刺, Unquoted chamfer 0.5, break sharp edges
- 2.各表面不得有划伤,锈迹等缺陷; All surfaces must be rust free and no scratch
- 3.未注尺寸公差按ISO 2768-MK标准; dimensions without tolerance according to 2768-MK
- 4.齿部淬火处理HRC4.0~4.5,涂防锈油; Teeth induction hardened HRC4.0-4.5, coated with antirust oil;
- 5.产品打字,装配紧定螺钉; Marking part No, Setscrews installed

标记	处数	更改文件号	签字	日期
设计		zhang		
审核		huang		
工艺				

名称/Name:	链轮
型号/Code:	40B,Z60
共	页
第	页

图号/Drawing No:	TRM4157_0	更新/Rev	
材料/Material:	C45	重量	
		比例	1:3
Chengdu Leno Machinery Co.,Ltd Tel:+86-28-65998825; Fax:+86-28-84862968 sales@cdleno.com; www.cdleno.com			